

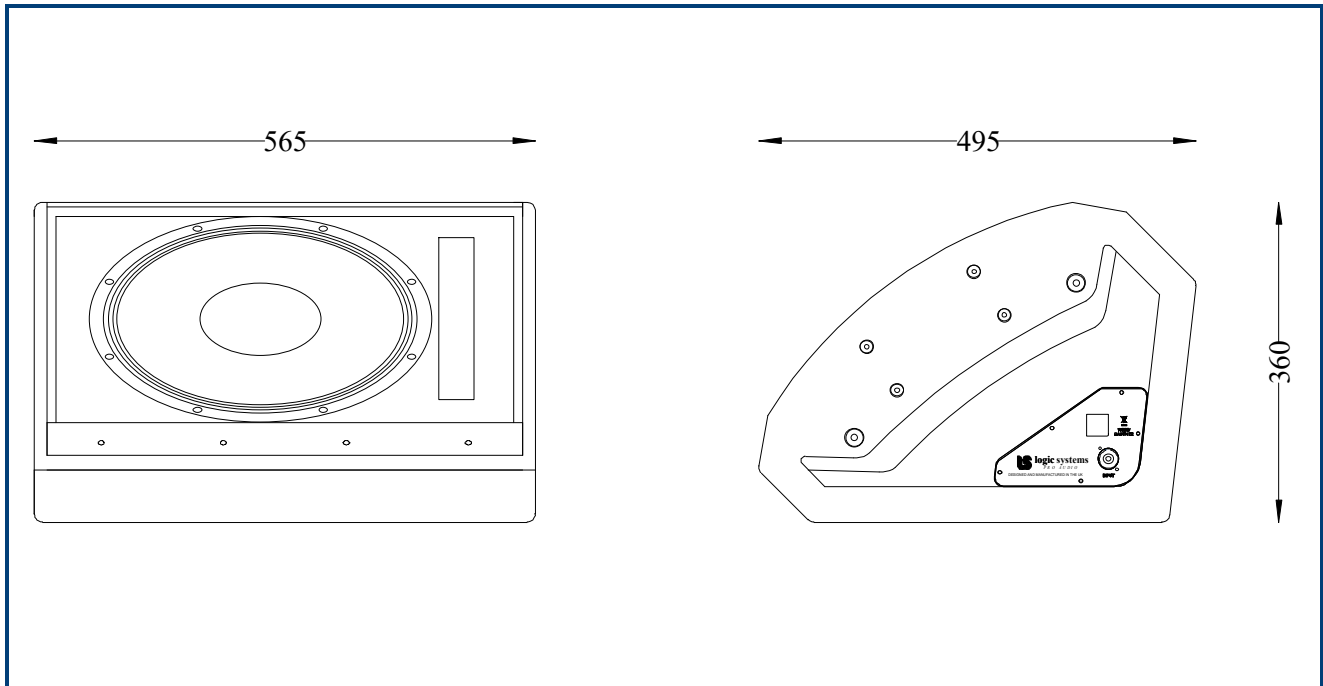

The MLM Series is a range of state of the art live sound stage monitors. The MLM15 cabinet combines a 15" Mid/Bass cone with a coaxially mounted 3" HF voice coil, which is passively crossed over. The coaxial layout has many acoustic advantages and also means that with a centrally mounted HF driver matched pairs are not required. To aid functionality the cabinet also benefits from a tophat mount which enables the cabinet to be used for small front of house applications. The monitor also benefits from being low profile to improve those all important sight lines. Another useful feature is link through speakons on the cabinet ends, ensuring neat cabling when used as pairs.



Frequency Response:	<ul style="list-style-type: none"> • 50Hz – 18kHz
Components:	<ul style="list-style-type: none"> • Bass/mid: 15" cone driver • HF: 3" voice coil, coaxially mounted
Power handling:	<ul style="list-style-type: none"> • 400w
Sensitivity (1):	<ul style="list-style-type: none"> • 97dB
Directivity:	<ul style="list-style-type: none"> • 60° conical above 1kHz
Impedance:	<ul style="list-style-type: none"> • 8 Ohms nominal
Construction:	<ul style="list-style-type: none"> • 15mm & 24mm Birch plywood
Finish:	<ul style="list-style-type: none"> • Water based textured black paint
Connections:	<ul style="list-style-type: none"> • 2 x Neutrik NL4 connectors • 1+/1- Input 2+/2- no connection
Dimensions:	<ul style="list-style-type: none"> • 565mm (W) x 360mm (H) x 495mm (D)
Packaged Dimensions:	<ul style="list-style-type: none"> • 580mm (W) x 790mm (H) x 530mm (D)
Weight:	<ul style="list-style-type: none"> • 27Kg

Cabinet	Handles	Tophat	M20	Castors	Bracket Pt.	Inserts/Fly Points
MLM15	Yes	Yes	No	No	Yes	Yes

Note: (1) Sensitivity measured at 1 metre with 2.83V, using band limited pink noise

E: sales@logicsystems.co.uk T: +44(0)1427 611791 w: www.logicsystems.co.uk