

Ethos Nd218i is an installation specific, high power, band pass, sub bass enclosure, which is designed to be, used with the Ethos VA & LA vertical array cabinets and Ethos CA fixed angle array. Nd218i also has further installation applications when combined with ML series cabinets. The enclosure employs two 18" long throw neodymium cone transducers, each mounted in their own-vented back cavity, while both drivers are also co-aligned into a V shaped front manifold. The Ethos Nd218i shares the width and depth of the companion Ethos Nd315i bass enclosure, enabling easy and compact stacking. Offering high power detailed sub bass response in a relatively compact package; the Ethos Nd218i is an integral element of any installed the Ethos array systems.

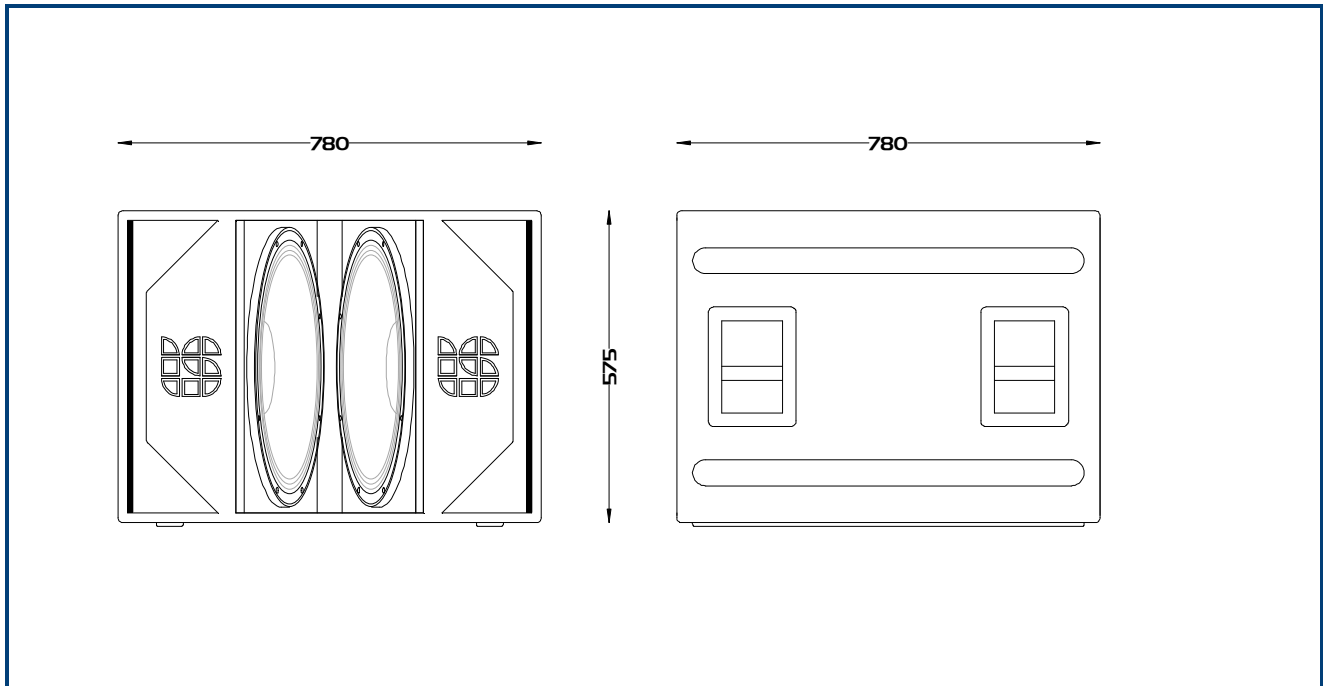

<b>Frequency Response:</b>	• 40Hz –100Hz
<b>Components:</b>	• Bass: 2 off 18" cone drivers
<b>Power handling:</b>	• 2400w
<b>Sensitivity (1):</b>	• 103 dB
<b>Directivity:</b>	• Omni-directional.
<b>Impedance:</b>	• 4 Ohm
<b>Construction:</b>	• 18mm Birch plywood
<b>Finish:</b>	• Water based textured black paint
<b>Connections:</b>	• 2 x Neutrik NL4 connectors. • Input on 1+/1-, 2+/2- linked through
<b>Dimensions:</b>	• 780mm (W) x 575mm (H) x 780mm (D)
<b>Packaged Dimensions:</b>	• 840mm (W) x 615mm (H) x 840mm (D)
<b>Weight:</b>	• 72Kg

Cabinet	Handles	Tophat	M20	Castors	Bracket Pt.	Inserts/Fly Points
<b>Nd218i</b>	4 off	No	No	No	No	No

**Note:** (1) Sensitivity measured at 1 metre with 2.83V, using band limited pink noise.