

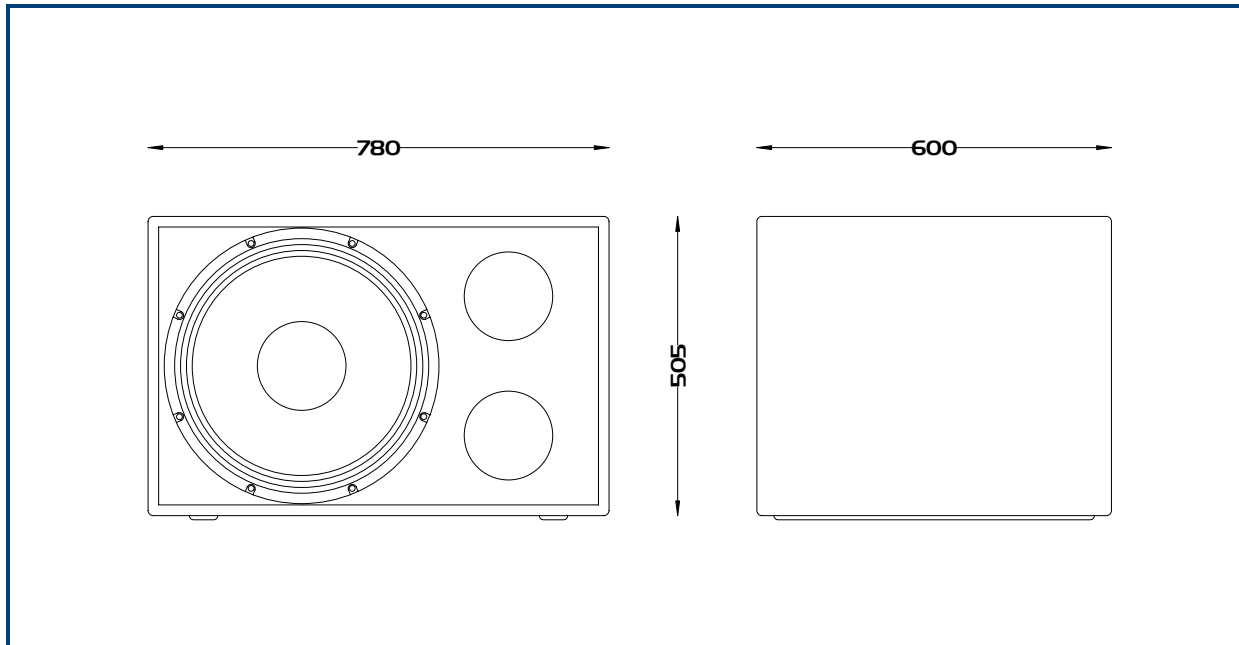

The Logic Systems SB180i is an installation specific compact, high power, sub/bass enclosure which features a band pass loaded 18" bass driver. Sonically the SB180i features the weight expected of an 18" driver, but also retains punch and control. The SB180i is designed to combine with ML and IS Series products within fixed installation and is an ideal partner cabinet for the B300i, both cabinets having identical dimensions and runner spacings. The Logic Systems DP2140 system controller contains presets for the integration of the Ethos SB180i with other Logic Systems products.



Frequency Response:	<ul style="list-style-type: none"> • 40Hz – 150Hz
Components:	<ul style="list-style-type: none"> • Bass: 1 x 18" cone driver • HF: N/A
Power handling:	<ul style="list-style-type: none"> • 1000w
Sensitivity (1):	<ul style="list-style-type: none"> • 98dB
Directivity:	<ul style="list-style-type: none"> • Omni-directional
Impedance:	<ul style="list-style-type: none"> • 8 Ohm
Construction:	<ul style="list-style-type: none"> • 18mm Birch plywood
Finish:	<ul style="list-style-type: none"> • Water based textured black paint
Connections:	<ul style="list-style-type: none"> • 2 x Neutrik NL4 connectors • 1+/1- Input 2+/2- Linked
Dimensions:	<ul style="list-style-type: none"> • 505mm (W) x 780mm (H) x 600mm (D)
Packaged Dimensions:	<ul style="list-style-type: none"> • 635mm (W) x 930mm (H) x 730mm(D)
Weight:	<ul style="list-style-type: none"> • 48g

Cabinet	Handles	Tophat	M20 plate	Castors	Bracket Pt.	Inserts/Fly Points
SB180i	4 off	No	No	No	No	No

Note: (1) Sensitivity measured at 1 metre with 2.83V, using band limited pink noise.